

Job Name	
Order No.	

# HITACHI

<b>Submittal Data Sheet</b>	<b>RAC-XJ12WHAA / RAK-XJ12PHAA</b>
<b>12,000 Btu/hr Wall Mounted Heat Pump System</b>	

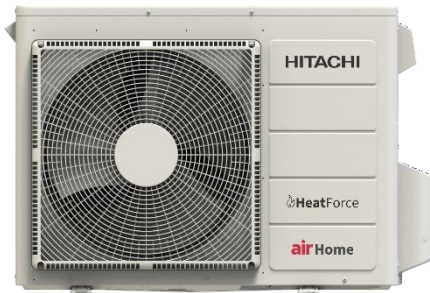

### Efficiency

Cooling		Heating	
SEER2	25	HSPF2	11.5
EER2	14.5	COP	3.12

### Performance

Cooling(Btu/hr)	
Rated(Min/Max)	12,500(5,000/14,000)
Sensible @AHRI	9,400
Operating Range	-5°F~114.8°F

Indoor: 80°F DB/67°F WB  
Outdoor: 95°F DB/75°F WB

### Heating(Btu/hr)

1: @ 47° Rated (Min/Max )	13,500(4,700/19,000)
2: @ 17° Rated	11,000
3: @ -5° Max: Capacity / COP	13,500/2.15
Operating Range	-22°F~75.2°F

1: Rated Heating Conditions: Indoor: 70°F DB/60°F WB  
Outdoor: 47°F DB/43°F WB  
2: Rated Heating Conditions: Indoor: 70°F DB/60°F WB  
Outdoor: 17°F DB/15°F WB  
3: Heating Conditions; Compressor  
Operating at Max Frequency: Indoor: 70°F DB/60°F WB  
Outdoor: 5°F DB/5°F WB

### Electrical

	208/60/1	230/60/1
System MCA	14	14
System MFA	25	25
Compressor RLA	10	10
Outdoor fan motor FLA	2.38	2.38
Outdoor fan motor W	47	47
Indoor fan motor FLA	0.56	0.56
Indoor fan motor W	38	38

MFA: Max. fuse amps MCA: Min. circuit amps (A) FLA: Full load amps (A)  
RLA: Rated load amps (A) W: Fan motor rated output (W)

### Piping

Liquid (in)	1/4
Gas (in)	3/8
Drain (in)	5/8
Max. Interunit Piping Length (ft)	100
Max. Interunit Height Difference (ft)	65.6
Chargeless (ft)	49
Additional Charge of Refrigerant (oz/ft)	0.11

### Indoor Specifications

	Cooling		Heating	
	Hi2	M	Hi2	M
Airflow Rate (cfm)	400	340	460	350
	L		L	
	270		220	
Sound (dBA)	48		48	
Dimensions (W x H x D) (in)	41.33 x 11.73 x 10.03			
Airflow Inlet (H x W) (in)	3.5 x 35.4			
Weight (Lbs)	30.07			

### Outdoor Specifications

Compressor	GTD130UKSA8JT8B		
Refrigerant	R32		
Factory Charge (Lbs)	2.65		
Refrigerant Oil	ACS-68R 440ml		
Airflow Rate (cfm)	Cooling	Heating	
	-	-	
Sound Pressure Level (dBA)	52		
Dimensions (W x H x D) (in)	33.46 x 25.59 x 11.73		
Weight (lbs)	91		

Recommended cable between Outdoor and Indoor 14AWG - 18AWG 4 conductors stranded copper wire and Power wiring cable size must comply with applicable national and local codes.

## Optional Accessories:

Description	Part Number
Remote Controller <b>(Included)</b> -HN1	PMK-XJ09PHAAR05
Remote Control Support (Included)	PMK-DJ09PHAAR06
Remote Controller French - HN3	PMK-XJ09PHAAR95
Wired Controller	SPX-URFG1
16.4 ft (5m) wire cable for SPX-URFG1	SPX-WKT5M
Wi-Fi Adapter	SPX-WFA03
H-Link Adapter IDU	PSC-6RAD
Adapter for Wired Remote Group Controller	SPX-DST1
26.2 ft (8m) Wire Cable for Distributor SPX-DST1	SPX-WDST8M
Dry Contact	SPX-WDC3
ON/OFF Status and Alarm Signal	SPX-WDC8
Mini Aqua Univolt 100V – 250V	DPWM-83819
Condenser Stand	DL87743
Condenser Wall Bracket	DL87733
5-Wire Thermostat / Wi-Fi / BACnet/Modbus Adapter	C1STAT01

# Dimensional Data:

## Indoor Unit:

MODEL: RAK-XJ09PHAA , RAK-XJ12PHAA

UNIT: Inch(mm)

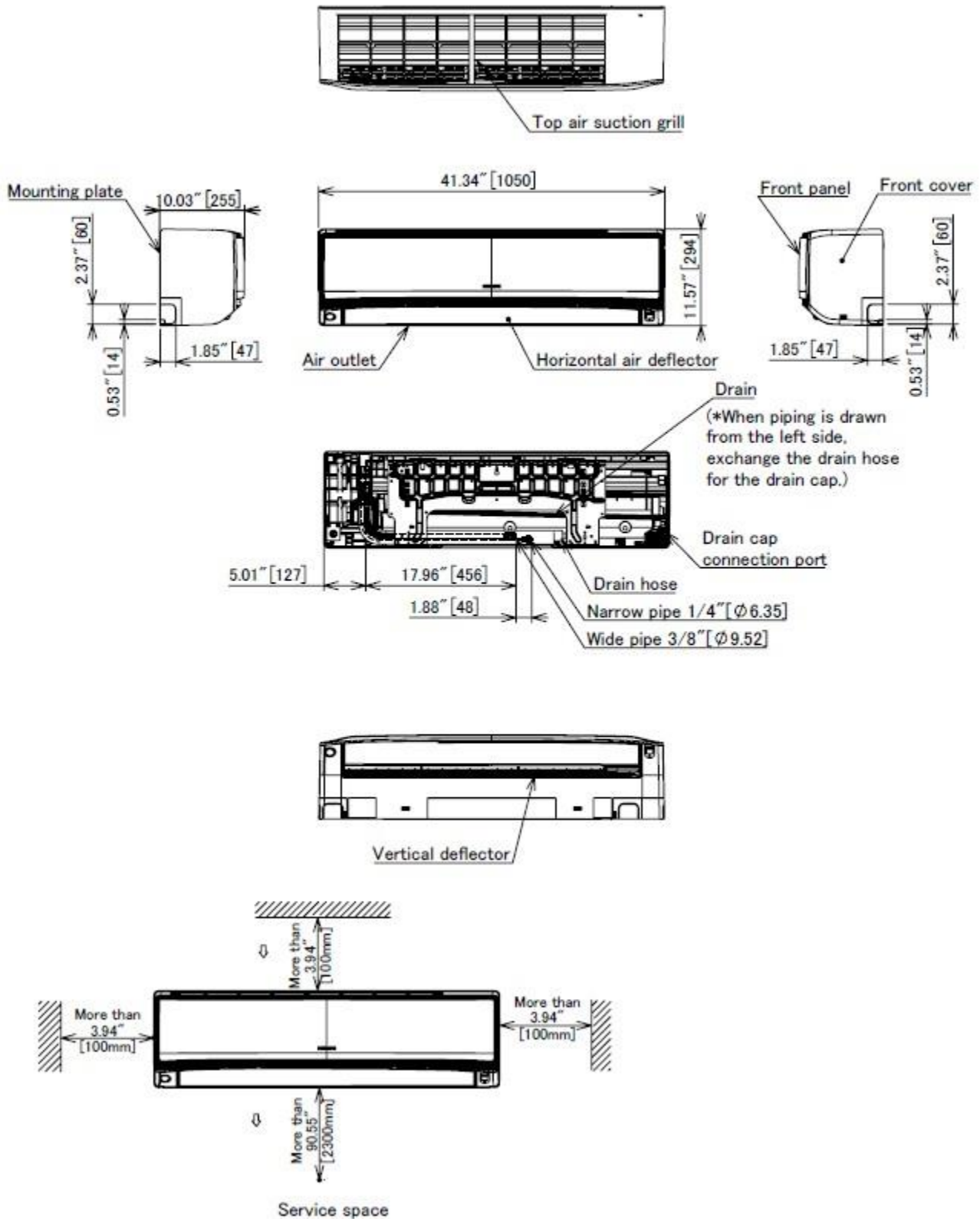

# Outdoor Unit:

MODEL RAC-XJ09WHAA  
RAC-XJ12WHAA

Unit: Inch (mm)

